



JEFF ROWLAND
DESIGN GROUP

OWNER'S MANUAL CAPRI STEREO PREAMPLIFIER



CAPRI S STEREO PREAMPLIFIER

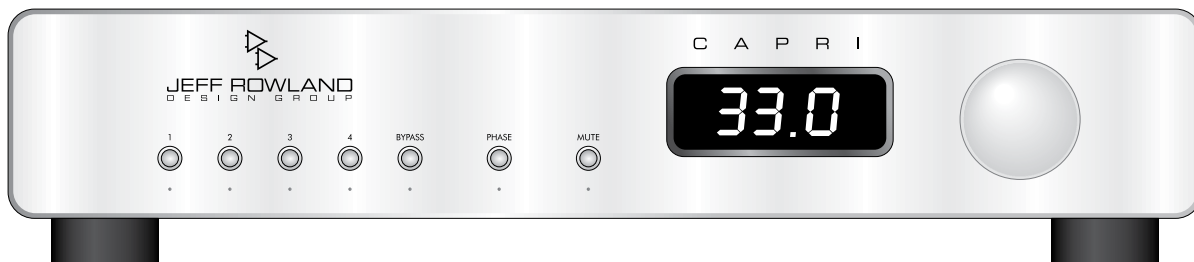

TABLE OF CONTENTS

OWNER'S MANUAL CAPRI/CAPRI S STEREO PREAMPLIFIER



Introduction	2	Remote Transmitter Operation	10-11
Product Features	3	Front Panel Functions	12-13
Package Contents	4	Rear Panel Signal Connections	14-15
Initial Inspection	5	Rear Panel Power Connections	16-17
Maintenance & Cleaning	6-7	Specifications	18
Protection Systems	7	Dimensions	19
Installation, Use & Care	8-9	Optional Adjustments	20-25

INTRODUCTION

OWNER'S MANUAL CAPRI/CAPRI S STEREO PREAMPLIFIER

Welcome to the Jeff Rowland Design Group “family” and congratulations on your purchase of what is unquestionably one of the world’s finest preamplifiers. With its combination of features such as precision electronic circuitry, exceptional efficiency, and accurately machined chassis components throughout, your CAPRI Stereo Preamplifier will offer you many years of musically satisfying enjoyment.

Please take a few minutes to read the remainder of this Owner’s Manual before proceeding with the installation of the

preamplifier. A thorough understanding of the operational features will allow you to gain the maximum performance and ease of use for which this preamplifier was designed. Please note that your CAPRI Stereo Preamplifier serial number begins with the letters “SE.” This serial number is located on the rear panel of the chassis. Please include this number with any correspondence regarding your CAPRI Stereo Preamplifier. It has been my joy to create an audio component of enduring value that reflects the highest ideals of musical and artistic expression. It is my hope that these qualities will enrich your experience and pride of ownership.

If you have any additional questions regarding the installation or operation of the CAPRI Stereo Preamplifier, please contact your authorized Jeff Rowland Design Group dealer or check the Jeff Rowland Design Group web site at www.jeffrowland.com.

Enjoy the music!



Jeff Rowland
President,
Jeff Rowland Design Group

PRODUCT FEATURES

OWNER'S MANUAL CAPRI/CAPRI S STEREO PREAMPLIFIER

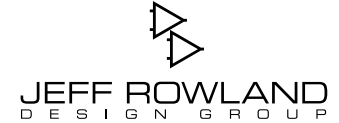

- Two pairs XLR input connectors for balanced system configurations.
- Two pairs RCA input connectors for unbalanced system configurations.
- One pair high-current, balanced line level outputs plus one pair RCA unbalanced outputs to allow for driving of multiple amplifiers for bi-amplification, subwoofers, etc.
- Fully-balanced inputs provide universal compatibility with other components and eliminate ground loop noise and EMI.
- Fully-balanced topology implemented in both input and output circuitry.
- Bypass function allows for transparent use in combination audio/home theater systems.
- Low noise, high-current, switch-mode power supply provides highest performance at any world-wide mains operating voltage.
- Low power consumption permits constant power-up operation to eliminate warm-up time.
- Optical encoder type volume control maintains quiet, trouble-free performance and accuracy over the entire lifetime of the product.
- Dual range volume control allows large volume level changes when knob is rotated abruptly, yet allows small, precise volume level changes when knob is rotated slowly.
- Six function, hand-held infrared remote transmitter.
- Ultra-low resonance, structurally rigid chassis, precision-machined from a solid block of aircraft grade 6061-T6 aluminum.
- Optional plug-in phono cards (installed internally) convert Line Input 1 to high performance phono inputs. Three gain and loading options can accommodate moving magnet (MM), moving coil (MC) cartridge types and high output moving coil cartridge types.

PACKAGE CONTENTS

OWNER'S MANUAL CAPRI/CAPRI S STEREO PREAMPLIFIER

Ensure that all of the auxiliary components listed below are enclosed within the shipping carton and accessory box. Refer to the illustrations and verify that the proper components are included.



CAPRI STEREO PREAMPLIFIER



REMOTE TRANSMITTER

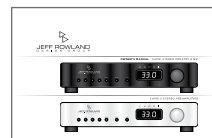

OWNER'S MANUAL

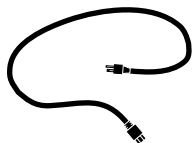

AC POWER CABLE



WARRANTY CARD

INITIAL INSPECTION

OWNER'S MANUAL CAPRI/CAPRI S STEREO PREAMPLIFIER



Inspect the shipping container for damage. If any portion of the shipping container, packing material, preamplifier, or accessories are damaged or missing, notify your dealer and the shipper (if a claim is to be made) immediately.

NOTE: Many shippers require notification and inspection within 24 hours of delivery to determine the nature of damages incurred.

Your CAPRI Stereo Preamplifier has undergone extensive performance evaluations, listening tests, quality control inspections, and a minimum 72 hour burn-in period prior to shipment and should therefore be in perfect operating condition upon delivery. If the preamplifier does not operate correctly, please notify your dealer immediately.

We strongly suggest that you save all of the packing materials. If the preamplifier is returned to your dealer or JRDG, the original packing materials must be used for shipment to avoid possible damage. Neither JRDG nor the shipper can be held responsible for damages incurred during transit if the original factory packing is not used. All factory returns require that JRDG issue a Return Authorization (RA) number prior to shipment.

MAINTENANCE & CLEANING

OWNER'S MANUAL CAPRI/CAPRI S STEREO PREAMPLIFIER

All JRDG products are designed to provide a lifetime of enjoyment and listening pleasure. The CAPRI Stereo Preamplifier is uniquely constructed from a solid block of precision-machined aluminum. It's chassis is sealed to prevent dust from entering the interior of the chassis and thus should never need interior cleaning during the lifetime of the product. All internal circuitry is maintenance-free such that no adjustments of any kind are necessary over the lifetime of the product. If the preamplifier is ever in need of service, updating, or upgrading, it should only be returned to an authorized repair facility or technician for servicing.

The front panel of the unit is precision-machined in a unique process that incorporates a diamond tipped cutting tool. This process was refined over many years to produce an attractive and unique appearance. Because the surface is not finished in the typical fashion of most audio and video equipment, there are a few rules that must be kept in mind when cleaning the equipment.

- Please allow the front panel, which is coated with an automotive-grade polyurethane finish, to cure for 6 months before attempting to clean it. This will prevent small scratches from marring the surface before the surface coating has had a chance to harden completely.
- The front panel of the unit should never be cleaned with anything other than a very soft cotton cloth and plain water or fine oil-based furniture polish. Because of the fine finish of the front panel, use of any other cleaning agent may permanently scratch the finish.
- The top cover, sides and bottom are protected by a durable black anodized finish and can be cleaned with a soft cotton cloth (such as an optical lens cleaning cloth or fine furniture polishing rag) dampened with plain water. Water should be applied directly to the cloth and not the chassis. A very mild plastic or glass cleaner that does not contain ammonia may also be used. If a mark has been left on the chassis, do not use any type of abrasive or chemical cleaner to remove the mark.

If you have any questions about the care or cleaning of your CAPRI Stereo Preamplifier, please contact your dealer or the JRDG factory before attempting to clean the chassis. The use of a cleanser or abrasive to clean the chassis that has not been approved by the factory will almost certainly damage the finish and will not be covered under warranty.

NOTE: Cleaner/polish should be applied directly to the cloth and not the chassis.

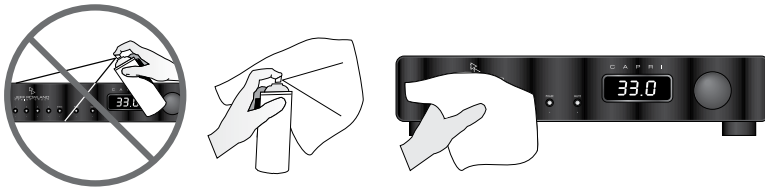

PROTECTION SYSTEMS

The CAPRI Stereo Preamplifier is equipped with internal fuses for protection against excessive AC current draw; however, since no protection circuitry or system can completely protect a product from every electrical hazard, certain precautions should be observed. In the event of severe voltage hazards such as lightning or when the preamplifier will not be used for extended periods of time, the preamplifier should be unplugged from the AC mains to avoid potential damage to the internal circuitry. All other audio/video system components should also be disconnected from AC mains power as hazardous voltages can easily travel throughout an interconnected system.

INSTALLATION, USE & CARE

OWNER'S MANUAL CAPRI/CAPRI S STEREO PREAMPLIFIER

Locate the preamplifier as close as possible to its final installation point. Allow access to the rear panel for making connections. Due to its design, the CAPRI Stereo Preamplifier is energy efficient, eliminating the need for heatsinks or forced-air cooling. As a result, the CAPRI Stereo Preamplifier can be housed in a cabinet or custom enclosure with no fear of overheating.

The efficient and compact design of the CAPRI allows it to be installed in any number of music, film and surround sound systems. For connection instructions for a typical two-channel stereo system, please see page 14 and 15 of this manual. For instructions regarding the use of the BYPASS INPUTS for surround sound or home theater system use, please see page 15 of this manual.

The main chassis of the CAPRI is precision-machined out of a solid block of aluminum to create as rigid an enclosure as possible, impervious to lateral and torsional forces. The preamplifier is particularly non-resonant; however, various damping and resonance control accessories may be used to yield greater audio performance in some audio systems.

The JRDG CAPRI Stereo Preamplifier has been designed to operate at the highest level of efficiency and performance in any normal operating situation; however, there are a few important use and care principles that must be kept in mind when operating the preamplifier:

- Do not expose the preamplifier to rain, moisture, or excessively damp conditions.
- Due to auto-ranging circuitry and dual-stage voltage regulation, the audio performance will not be affected by any voltage fluctuations within the operating voltage range. The CAPRI Stereo Preamplifier can be operated at any mains voltage over the range of 85 to 265 VAC without any adjustments necessary.
- The CAPRI Stereo Preamplifier must not be modified in any way, other than according to official service bulletins from JRDG. Otherwise, the factory warranty will be immediately voided.
- Be sure the preamplifier is muted (red front panel indicator light on) before connecting or disconnecting any interconnect cables.
- When operating the CAPRI, a properly grounded AC receptacle should be used. A potential shock hazard may result if the supplied 3-wire, grounded AC cable ground terminal is defeated or lifted or the unit is connected to a 2-wire ungrounded AC outlet.
- The CAPRI is designed to perform optimally with no adjustments or maintenance for the lifetime of the product. Do not attempt to open the bottom cover of the preamplifier and refer all service issues to qualified personnel. The voltages inside the CAPRI can be hazardous.
- Because of the energy efficiency of the CAPRI, there is no need to unplug the unit when not in use; however, the preamplifier can be muted if desired.

REMOTE TRANSMITTER OPERATION

OWNER'S MANUAL CAPRI/CAPRI S STEREO PREAMPLIFIER

The CAPRI Stereo Preamplifier is equipped with a wireless, infrared (IR) remote transmitter, allowing convenient wireless control of the most commonly used functions from the listening position. An explanation of these functions and battery installation follows.

NOTE: Placing the preamplifier in extremely high ambient light conditions may cause erratic remote control operation. The IR sensor, located within the volume level display, must not be exposed to direct sunlight or spotlights.

(1) INPUT SELECT: This button will select the desired input, the input number corresponding to the numbering of the inputs on the rear panel. Each press of this button will scroll to the next successive input. Once Input 4 has been reached, the next press of the INPUT button will select the BYPASS input. Another press of the INPUT button will return the selection to Input 1.

(2) MUTE: This button will immediately mute the outputs of the preamplifier. The volume display will continue to show the present location of the volume control. Pressing this button a second time will reactivate the outputs of the preamplifier.

(3) VOLUME ▲: The VOLUME UP button will increase the output level of the preamplifier in 0.5 dB increments. Holding this button down will cause the volume level to continuously increase until the button is released or until 99.5 is displayed on the volume display.

(4) VOLUME ▼: The VOLUME DOWN button will decrease the output level of the preamplifier in 0.5 dB increments. Holding this button down will cause the volume level to continuously decrease until the button is released or until 00.0 is displayed on the volume display.

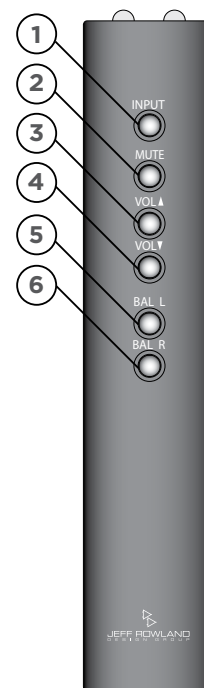

(5) BAL L: This button will shift the output of the preamplifier towards the left channel. Each press of the button will increase the output of left channel by 0.5 dB and decrease the level of the right channel by 0.5 dB. A total shift of 6 dB is possible. The balance control is not continuous; holding the button down will not continue to shift the balance. The button must be repeatedly pressed to continue to activate the balance shift towards the left channel.

(6) BAL R: This button will shift the output of the preamplifier towards the right channel. Each press of the button will increase the output of right channel by 0.5 dB and decrease the level of the left channel by 0.5 dB. A total shift of 6 dB is possible. The balance control is not continuous; holding the button down will not continue to shift the balance. The button must be repeatedly pressed to continue to activate the balance shift towards the right channel.

NOTE: To return the balance to the center or 0 dB position, press and hold the MUTE button on the front panel of the preamplifier for 3 seconds. This will reset all microprocessor controlled functions and return the balance position to L/R +/-0 dB.

(7) BATTERY REPLACEMENT: When the remote begins to become weak or will not function, it is likely necessary to replace the battery. Access to the battery is gained by removing the two Phillips head screws that secure the back cover of the remote transmitter unit. The old battery can be removed from the snap-on BATTERY TERMINAL and a new battery reinstalled. A standard alkaline battery is recommended.

NOTE: When removing the old battery, wait at least 30 minutes before installing a new battery to allow the internal circuitry to discharge completely and reset.

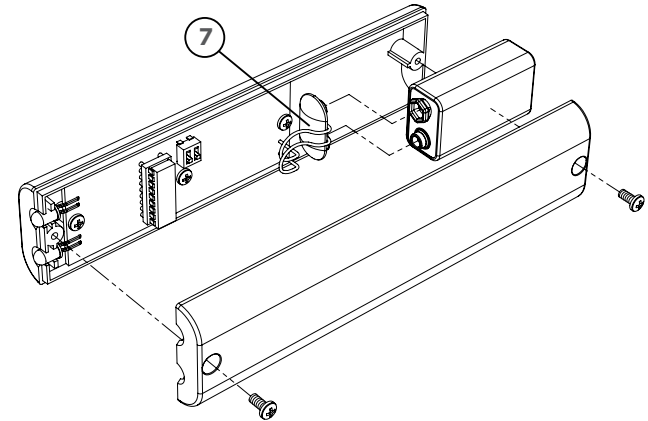

FRONT PANEL FUNCTIONS

OWNER'S MANUAL CAPRI/CAPRI S STEREO PREAMPLIFIER

Before attempting any system interconnection, please familiarize yourself with the front panel controls and indicators of the CAPRI Stereo Preamplifier. The descriptions refer to the illustration below.

(1) INPUT INDICATORS: Inputs 1 through 4 have a small indicator light below the Input Selector Buttons. An indicator will illuminate green when selected to show that the input is currently active.

(2) INPUT SELECTOR BUTTONS: Pressing these buttons selects an input source (CD, tuner, phono, etc.) connected to the associated rear panel inputs (see Rear Panel Signal Connections on page 14). To select a desired input, press the corresponding Input Selector Button. When an input is activated, the small, green Input Indicator below the Input Selector Button will illuminate.

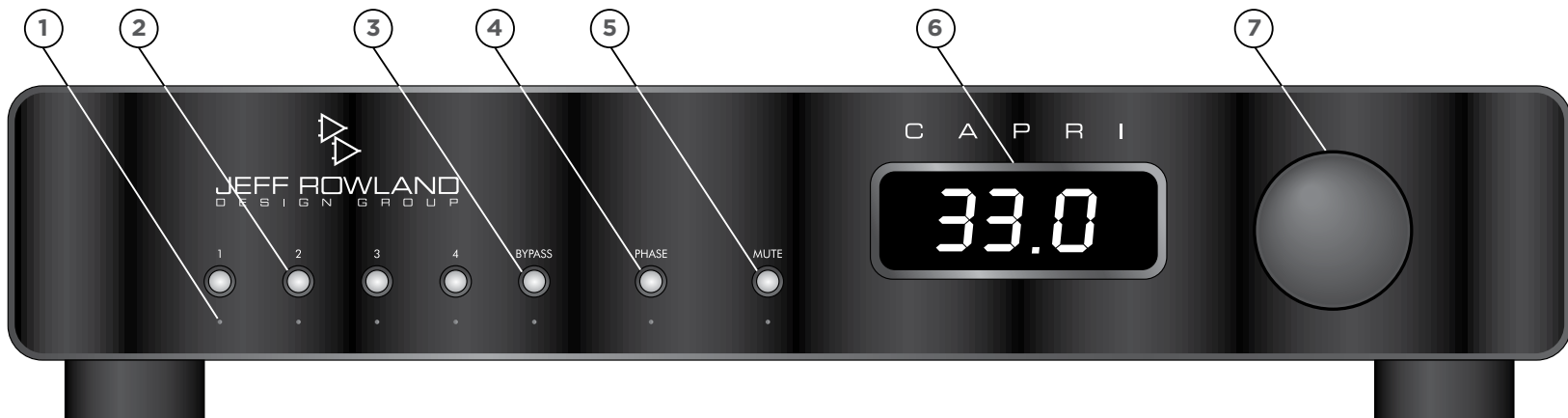

(3) BYPASS MODE: The Bypass Mode allows the CAPRI to be installed in a home theater or surround sound system for optimal playback of stereo music sources when the multi-channel system is not in use. Pressing this button will allow a multi-channel processor to bypass the preamplifier functions of the CAPRI, with the volume controlled only by the external processor. The indicator light below the BYPASS button will illuminate yellow to show that the Bypass function is active.

NOTE: Do not connect a source component to the BYPASS INPUTS if it does not have its own volume control. The volume control of the CAPRI Stereo Preamplifier is inactive when Bypass Mode is selected.

(4) PHASE: Pressing this button will invert the phase of both channels of the selected input and illuminate the yellow indicator light below the PHASE button. Pressing this button again will turn off the light and return the phase to uninverted polarity.

(5) MUTE MODE: Pressing the MUTE button will mute the speaker and line outputs of the CAPRI and illuminate the red indicator light below the MUTE button. Pressing this button again will turn off the light and restore the output of the preamplifier to the previous volume setting.

To avoid spurious noises and possible damage to other system components, the preamplifier should be muted when connecting or disconnecting any rear panel connections.

(6) VOLUME DISPLAY: This display shows the current volume of the selected input numerically, from 00.0 to 99.5, in 0.5 dB increments. If desired, the volume display can be configured to turn off 5 seconds after receiving any command from the front panel or the Remote Transmitter. Please contact your dealer about this function. The volume display also contains the infrared (IR) receiver for receiving remote commands.

(7) VOLUME CONTROL: Rotation of the volume control knob clockwise will increase the output level of the CAPRI. Rotation of the knob counter-clockwise will decrease the output level. The CAPRI features a dual-range volume control system: rotating the volume knob slowly will cause the volume to increase or decrease in small, precise steps. Rotating the knob abruptly will result in large, immediate changes to the output level.

NOTE: When the volume control is set to 85.5, the preamplifier is set for unity (0 dB) gain from any input to any output.

REAR PANEL SIGNAL CONNECTIONS

OWNER'S MANUAL CAPRI/CAPRI S STEREO PREAMPLIFIER

The CAPRI Stereo Preamplifier offers unprecedented compatibility with associated audio and A/V components. When connecting or disconnecting interconnect cables, the preamplifier should be placed in Mute Mode (red MUTE indicator LED on the front panel ON).

(1) UNBALANCED INPUTS: If you are using unbalanced RCA interconnects from your source components (CD player, tuner, etc.), they should be connected to unbalanced INPUTS 1 and 2. If you have had the optional phono section installed in the CAPRI, the interconnects from the turntable should be installed into INPUT 1. For more information about the phono option, please contact your dealer.

NOTE: To prevent audible pops when switching between inputs, install RCA "shorting" plugs, available from your JRDG dealer, into all unused RCA unbalanced inputs.

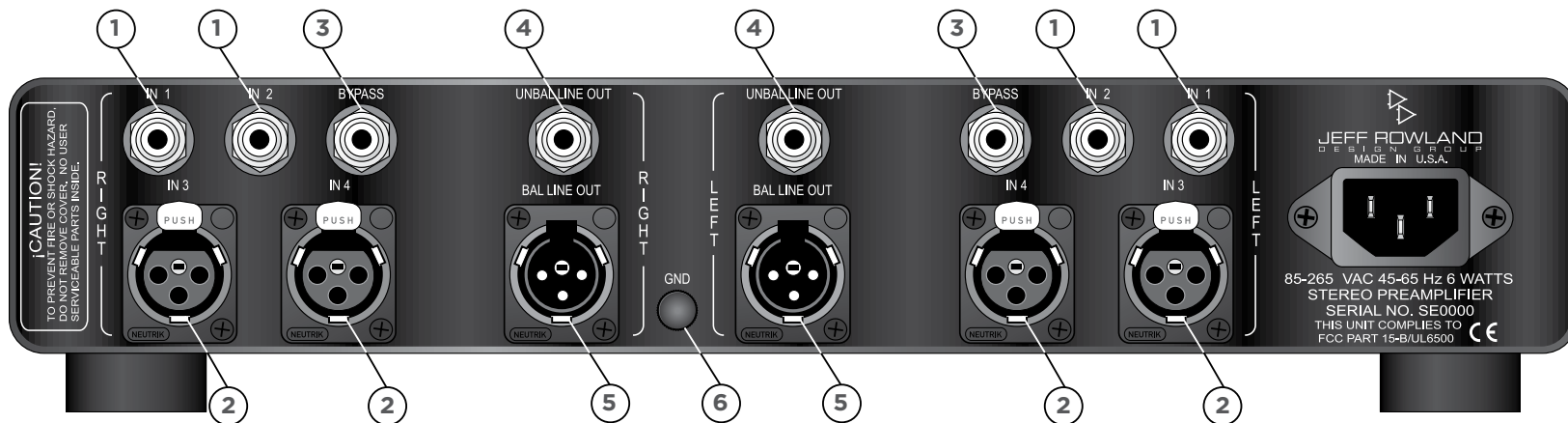

(2) BALANCED INPUTS: If you are using balanced XLR interconnects from your source components, they should be connected to balanced INPUTS 3 and 4. A slight mechanical click may be heard when the balanced XLR interconnect cables are correctly installed and locked into the rear panel connector. The unlocking tab must be pressed to disconnect the XLR interconnect cable from the preamplifier. The XLR inputs may be left open if unused. Any XLR input can be converted to an RCA input by installing an XLR to RCA adapter, available from your JRDG dealer.

NOTE: Pin 2 of each XLR connector is signal positive with respect to each RCA input. Also, JRDG recommends balanced cables as the preferred method of interconnection.

(3) BYPASS INPUTS: If the CAPRI is installed in a home theater or sound system, the Left Front and Right Front output connections from the surround processor should be installed in the BYPASS input connections. The CAPRI will only accept unbalanced RCA interconnects from the surround processor.

NOTE: If an external surround sound processor is not connected, install RCA “shorting” plugs to both bypass inputs.

(4) UNBALANCED LINE OUTPUTS: The CAPRI also has one pair of RCA unbalanced line level outputs. Use these outputs if your amplifier does not accept balanced inputs. Also, these outputs can be used simultaneously with the balanced inputs to feed a second amplifier (subwoofer, etc.)

NOTE: Do NOT install RCA “shorting” plugs in the unbalanced line outputs.

(5) BALANCED LINE OUTPUTS: The CAPRI has one pair of balanced preamplifier line level outputs. For best results, use these outputs to connect to your power preamplifier whenever possible. If two sets of single-ended outputs are required then the balanced line outputs can be converted to single-ended RCA outputs. JRDG recommends a single-ended adaptor box (Model PC-2XR) available from Jensen Transformers, www.jensen-transformers.com.

NOTE: Pin 2 of each XLR connector is signal positive with respect to each input and each unbalanced output.

(6) GROUND LUG THUMBSCREW: This connection is reserved for units with the optional phono section installed. When connecting a turntable, the ground or earth lead should be connected to the Ground Lug Thumbscrew to eliminate any ground noise in the system.

REAR PANEL POWER CONNECTIONS

OWNER'S MANUAL CAPRI/CAPRI S STEREO PREAMPLIFIER

Install the AC Power Cable into the AC input connector (A) between the preamplifier and your AC mains outlet.

! WARNING: If the unit is plugged into a voltage different from the range listed on the back panel, it will result in serious damage and will void the warranty.



POWER CONDITIONING: AC power conditioners and custom AC mains power cables are a common accessory in many high performance audio and video systems and can be used to improve the quality of music reproduction in certain instances. We have supplied the best possible basic power cord with the CAPRI; however, many users may wish to use aftermarket AC power cords available from many cable manufacturers. Since we have not found an optimal universal power conditioner or cable we cannot recommend any particular type or brand for use with the CAPRI. Please use your dealer's help and knowledge as a resource to select the proper accessories for your individual system needs.

NOTE: Due to the exceptionally low power consumption rating of the CAPRI Stereo Preamplifier, it is recommended that it not be disconnected from AC mains unless it is to be moved or reinstalled in another location. It is recommended that the unit simply be left on when not in use.



WARNING: Serious damage to internal circuitry can occur if improperly wired or unapproved AC power cords are used. Your dealer can be a helpful resource for selecting the proper accessories based on your needs.

SPECIFICATIONS

OWNER'S MANUAL CAPRI/CAPRI S STEREO PREAMPLIFIER

Overall Gain	14 dB
Gain Range	99.5 dB, 199 Equal Increments
Gain Resolution	0.5 dB, +/- 0.03 dB Over Entire Range
Frequency Response	10 Hz – 350 kHz, -3 dB @ 8 ohms
Maximum Input Level	13.5 volts (RMS) @ 0 dB gain
Maximum Output Level	13.5 volts (RMS)
THD + Noise	< .001% @ 2 volt (RMS) Output, 20 Hz – 20 kHz
Signal-to-Noise Ratio	> 100 dB
Common Mode Rejection Ratio	> 85 dB, 20 Hz – 20 kHz
Channel Separation	> 105 dB, 20 Hz – 20 kHz
Input Impedance	48K ohms Balanced or Unbalanced
Output Impedance	80 ohms Balanced, 40 ohms Unbalanced
Inputs	2 pair Balanced (XLR) 1 pair Unbalanced (RCA) Unity Gain (Bypass) 2 pair Unbalanced (RCA)
Outputs	1 pair Balanced (XLR) Line Level 1 pair Unbalanced (RCA) Line Level
Power Consumption	6 watts
Preamplifier Weight	9.5 lbs. / 4.26 kg
Overall Preamplifier Dimensions (H) x (W) x (D)	2.9" x 13.7" x 7.5" 74mm x 348mm x 192mm

DIMENSIONS

OWNER'S MANUAL CAPRI/CAPRI S STEREO PREAMPLIFIER

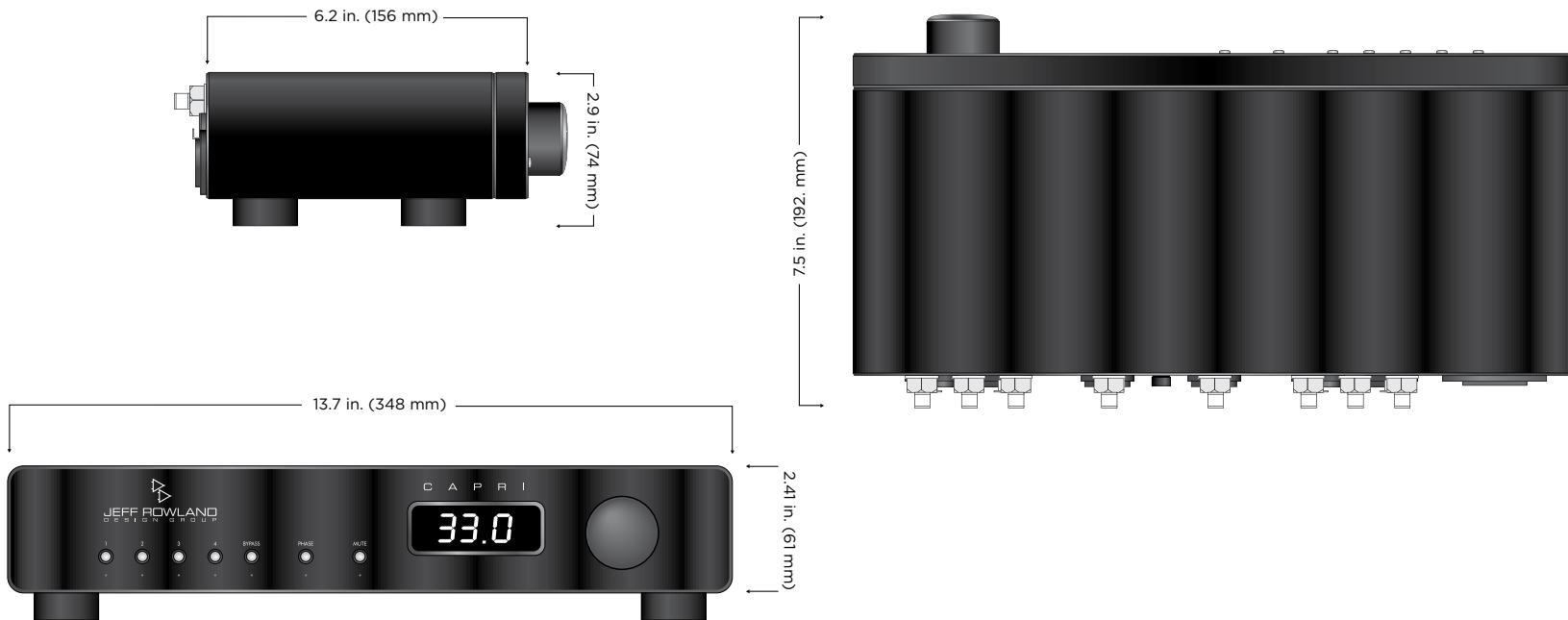

OPTIONAL ADJUSTMENTS

OWNER'S MANUAL CAPRI/CAPRI S STEREO PREAMPLIFIER

RISK OF ELECTRICAL SHOCK!

⚡ WARNING: The instructions in this section are meant for qualified JRDG service personnel only; however, if you as an end user choose to attempt these adjustments yourself, JRDG cannot be held liable for any damage that may occur to your CAPRI Stereo Preamplifier because of your actions. Further, accessing the interior of your CAPRI by removing the bottom Cover can expose you to dangerous, potentially lethal electrical voltages. Thus, JRDG cannot be held liable for any injury you may sustain should you undertake any of these adjustments yourself.

DISPLAY BLANKING ADJUSTMENTS

The display of the CAPRI can be configured to turn off (“go blank”) five seconds after each user command, whether from the front panel controls or from the remote control.

STEP 1: Unplug the CAPRI power cable from the wall AC outlet.

STEP 2: Place the unit upside-down on a soft, clean surface. Using a 5/64" hex wrench, remove the nine screws that secure the bottom cover of the unit.

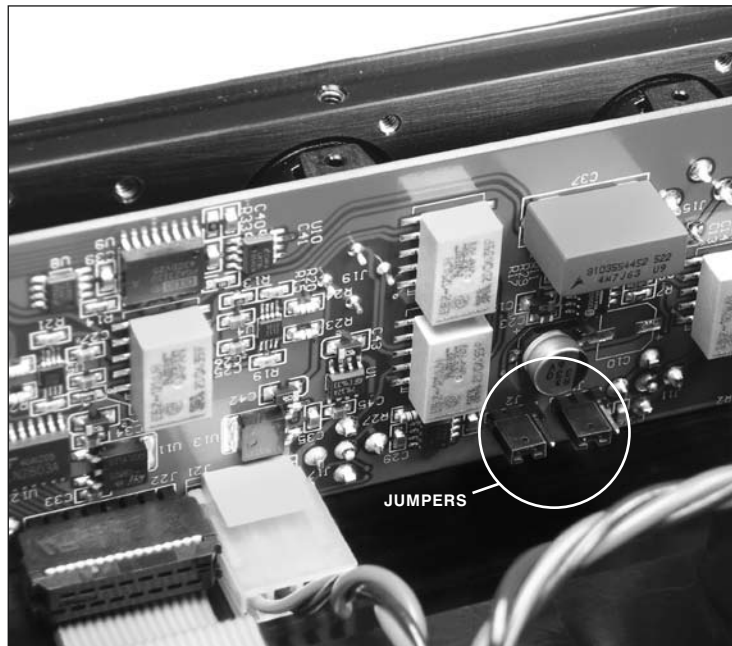

FIGURE 1: Location of jumpers within the chassis

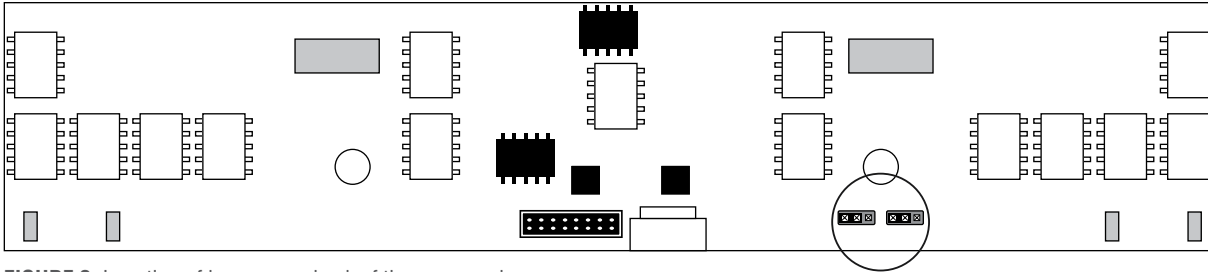

FIGURE 2: Location of jumpers on back of the rear panel

JUMPERS
DEFAULT POSITIONS SHOWN

STEP 3: Locate jumper position J2 on the rear panel board of the unit. Using needle-nose pliers, move the jumper from between pins 1 and 2 to pins 2 and 3, **DISPLAY BLANKING ON.** (See FIGURES 2 and 3)

STEP 4: Replace the bottom cover. Using a 5/64" hex wrench, reinstall the nine screws that secure the bottom cover to the chassis.

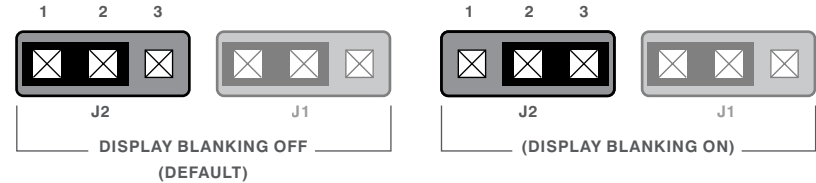

FIGURE 3: Jumpers J1-J2; Close-up of Display Blanking settings for the CAPRI

OPTIONAL ADJUSTMENTS

OWNER'S MANUAL CAPRI/CAPRI S STEREO PREAMPLIFIER

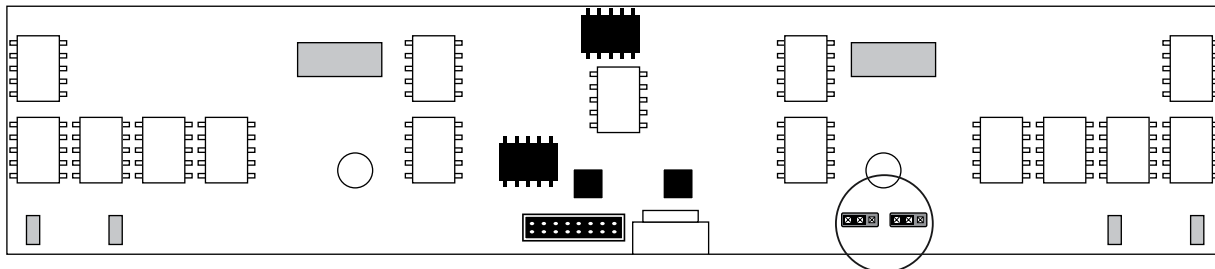

FIGURE 4: Location of jumpers on back of the rear panel

JUMPERS

DEFAULT POSITIONS SHOWN

REMOTE CONTROL FREQUENCY

A second remote control operational frequency may be selected for the CAPRI if interference occurs when using the factory-default settings. This interference could occur either from the CAPRI's remote interfering with other equipment or vice versa.

STEP 1: Unplug the CAPRI power cable from the wall AC outlet.

STEP 2: Place the unit upside-down on a soft, clean surface. Using a 5/64" hex wrench, remove the nine screws that secure the bottom cover.

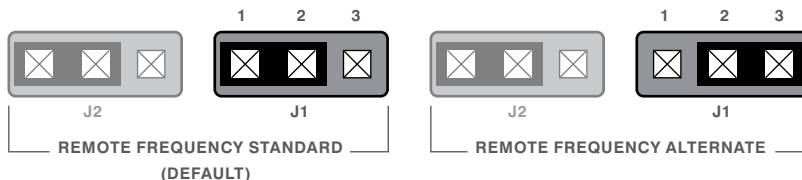

FIGURE 5: Jumpers J1-J2; Close-up of Remote Control Frequency settings for the CAPRI

STEP 3: Locate jumper position J1 on the rear panel board of the unit. Using needle-nose pliers, move the jumper from between pins 1 and 2 to pins 2 and 3. (See FIGURES 4 and 5)

STEP 4: Replace the bottom cover. Using a 5/64" hex wrench, reinstall the nine screws that secure the bottom cover to the CAPRI chassis.

STEP 5: Using a #1 Phillips head screwdriver, remove the two screws that secure the remote transmitter housing. Open the housing.

STEP 6: Locate switch position SW7. Adjust slider #1 on the switch. This switch now corresponds with the new setting on jumper J1 of the rear panel board.

STEP 7: Test the remote with the CAPRI Stereo Preamplifier to make sure that the units operate properly together.

STEP 8: After verifying proper operation, replace the remote housing and reinstall the two screws that secure the housing.

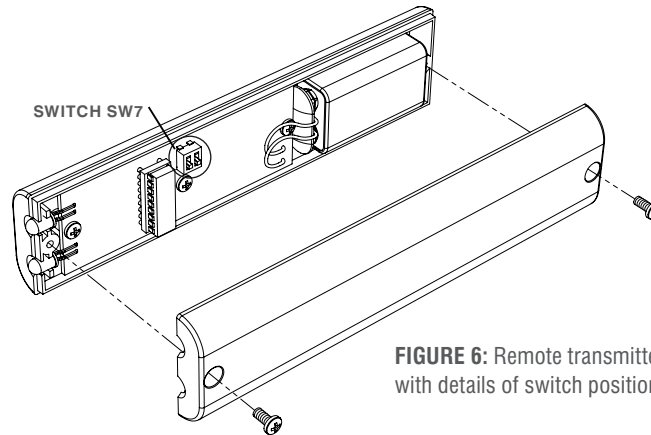
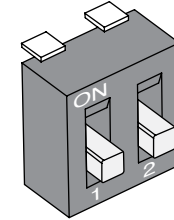
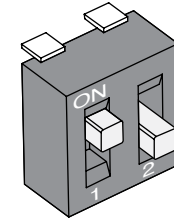

FIGURE 6: Remote transmitter housing with details of switch position SW7



SWITCH SW7 POSITION 1 (DEFAULT)



SWITCH SW7 POSITION 2

FIGURE 7: Detail of switch position SW7

OPTIONAL ADJUSTMENTS

OWNER'S MANUAL CAPRI/CAPRI S STEREO PREAMPLIFIER

PHONO CARD ADJUSTMENTS

If the Phono Card option has been factory installed, so that INPUT 1 on the rear of the CAPRI is dedicated for phono operation only, the following adjustments can be made to optimize the performance of a particular phono cartridge. These adjustments include both cartridge loading and overall phono amplifier gain.

STEP 1: Unplug the CAPRI Stereo Preamplifier power cable from the wall AC outlet.

STEP 2: Place the unit upside-down on a soft, clean surface. Using a 5/64" hex wrench, remove the nine screws that secure the bottom cover of the unit.

STEP 3: Locate and remove the phono card from the back panel by easing it gently back and forth until it separates from the unit. (See FIGURES 7 and 8)

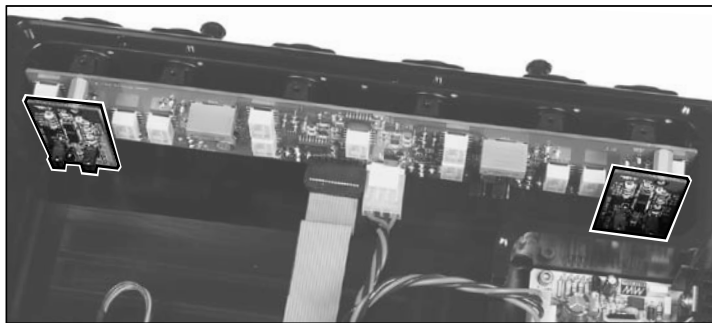

FIGURE 7: Location of both Phono Cards within the CAPRI chassis

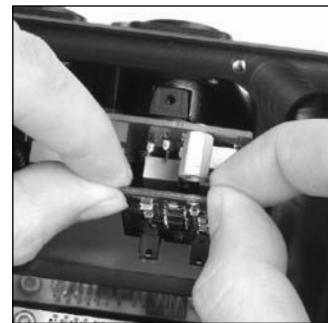

FIGURE 8: Detail of Phono Card PCB

CAUTION: Do not select the 47K ohm Load Switch Position unless a turntable, phono cartridge or RCA “shorting” plug is connected to INPUT1! If a phono turntable or RCA “shorting” plug is not connected to INPUT 1/and the card is installed, set the Load Switch Position to any position except 47K. The 47K ohm Load Switch Position is used for Moving Magnet or High Output Moving Coil phono cartridges only!

FIGURE 9: CAPRI Phono Card Details

STEP 4: Adjust the Load Resistance and Gain settings on the plug-in Phono Card as shown in FIGURE 9.

STEP 5: Replace the bottom cover. Using a 5/64" hex wrench, reinstall the nine screws that secure the bottom cover to the chassis.

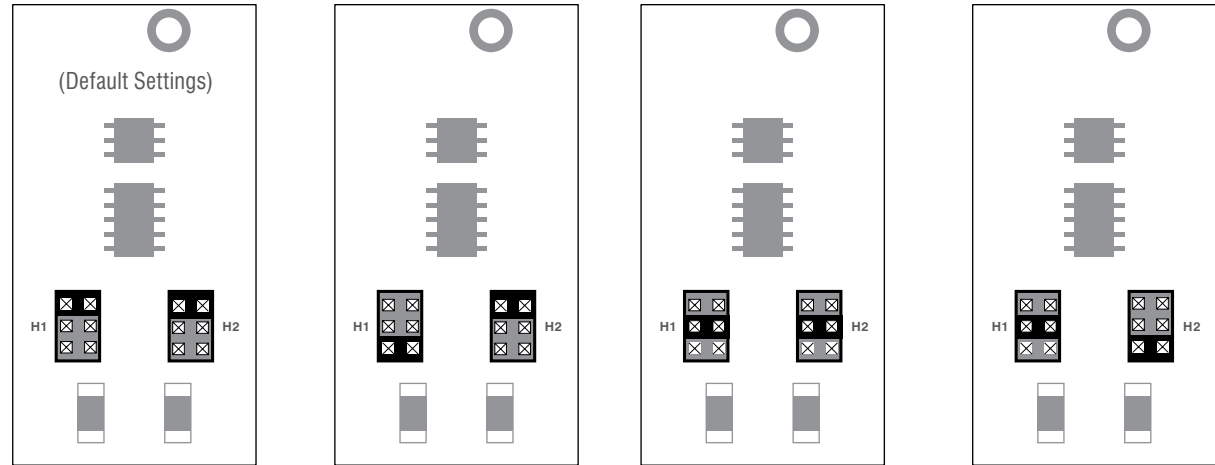

Gain=60 dB, Load=400 ohms: Settings used for Moving Coil cartridges only.

Gain=60 dB, Load=100 ohms: Settings used for Moving Coil cartridges only.

Gain=40 dB, Load=47K ohms: Settings used for Moving Magnet cartridges only.

Gain=50 dB, Load=47K ohms: Settings used for High Output Moving Coil.

H1: LOAD RESISTANCE SETTINGS: Settings in order from top to bottom: 400 ohm, 47K ohm, 100 ohm

H2: GAIN SETTINGS: Settings in order from top to bottom: 60 dB, 40 dB, 50 dB



JEFF ROWLAND
DESIGN GROUP
